

1/16" DOWEL LEADING EDGES

CONTOUR TIPS

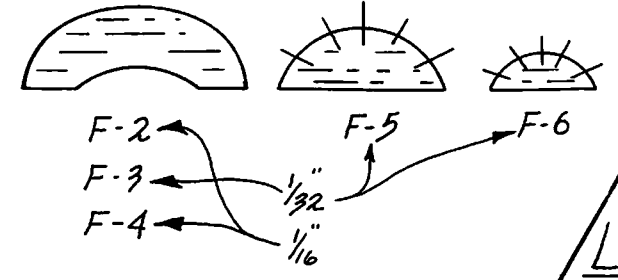
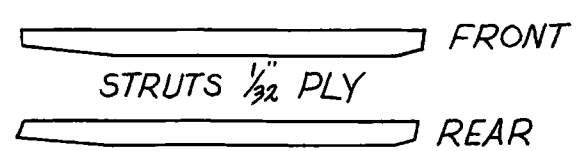
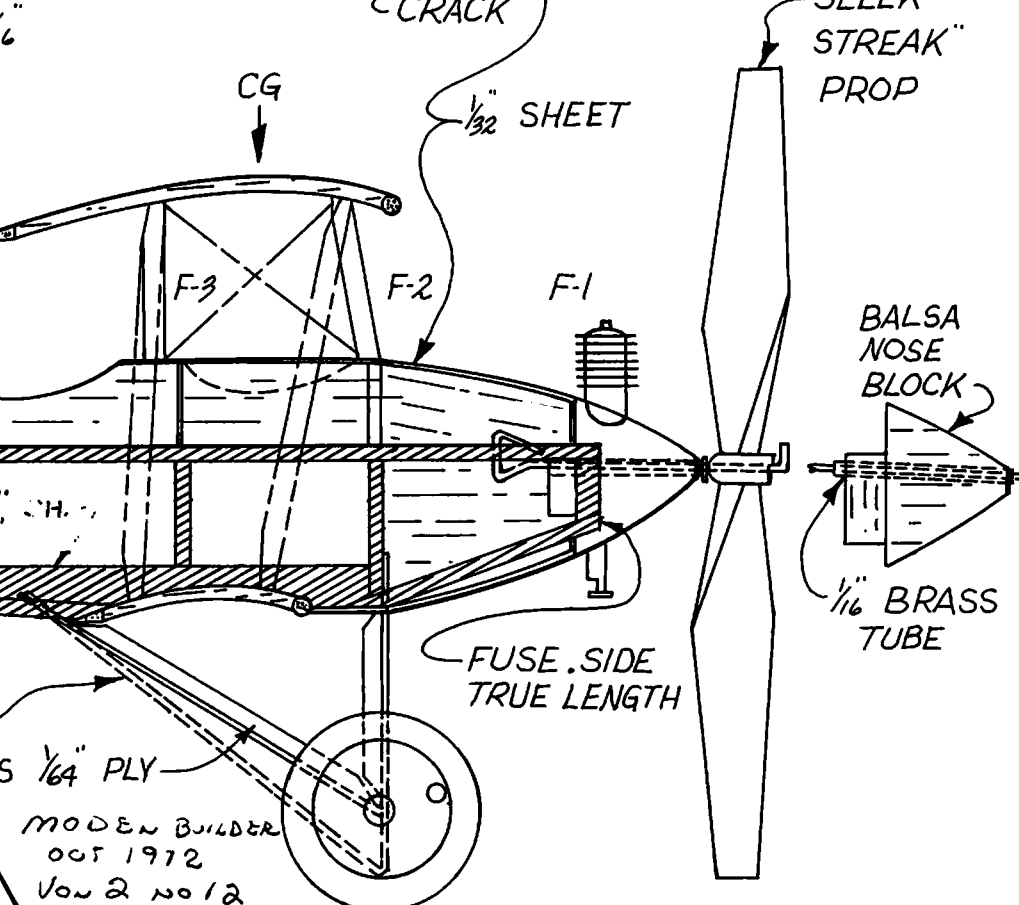
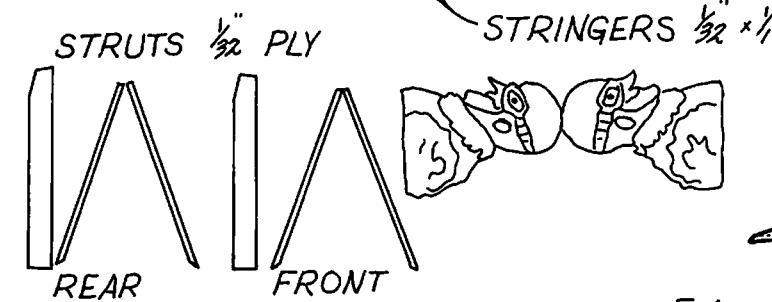
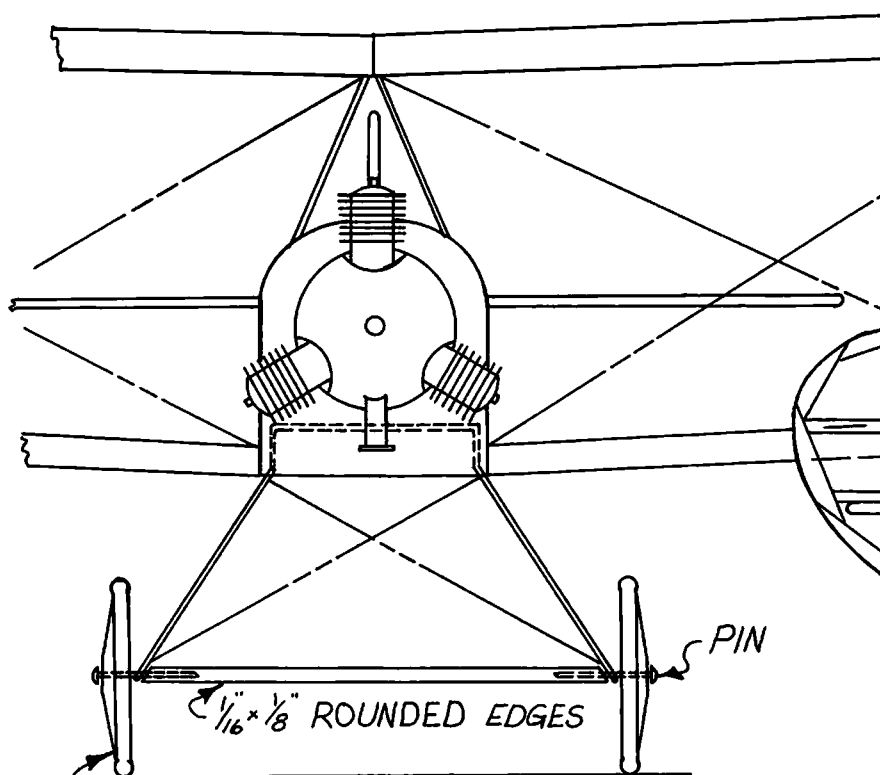
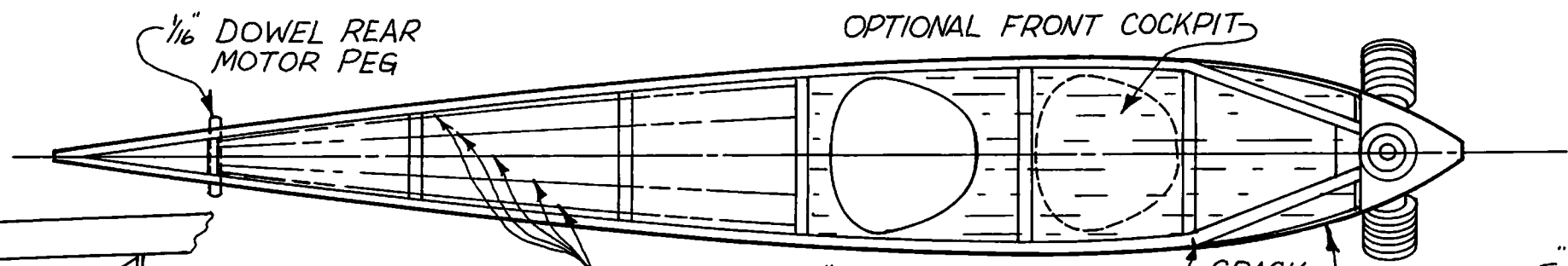
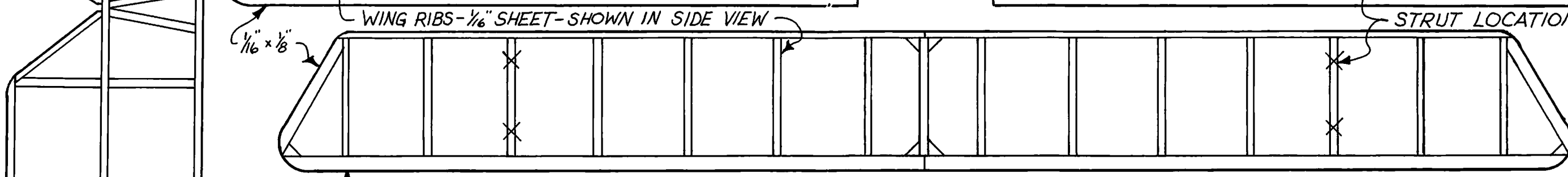
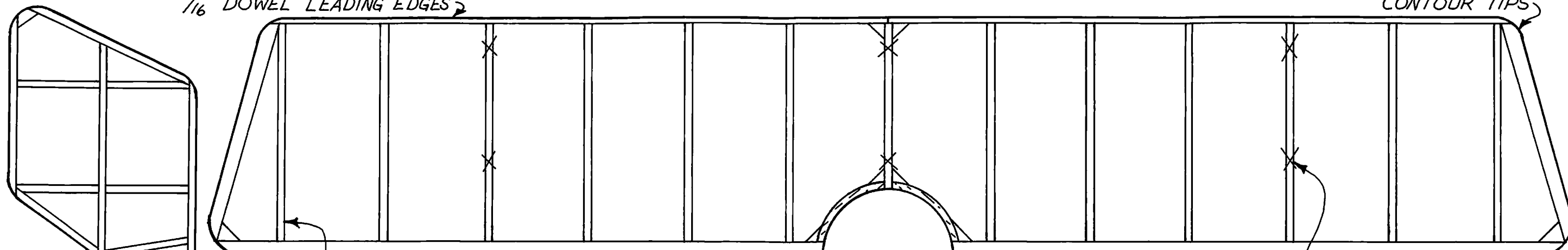

BELLANCA LIGHT TRACTOR

MODERN BUILDER
005 1972
Vol 2 no 12

DON BUTMAN AUG 1972