



# General Aviation Skyfarer

By EARL STAHL . . . One of pre-war modeling's legendary designers appears again, with the same precise drawings and building craftsmanship. Yes, the Skyfarer was published years ago, but to a smaller scale.

• Over the years, much attention has been directed by aerodynamicists to reducing the frequency and severity of aircraft accidents. One approach has been to eradicate the capability of light planes to spin after a stall. Toward this end, several spin-proof designs were commercially produced. The most notable was the Ercoupe, which was developed before, and sold in fairly large numbers immediately after World War II. Another "characteristically incapable of spinning" light plane, which reached production in the same period, was the General Aviation GI-80 Skyfarer.

Different design concepts were employed to make the two aircraft spin-

proof. The Ercoupe had interconnected ailerons and rudders; upward travel of the elevator was limited to restrict the capability of the pilot to raise the nose excessively. The Skyfarer, in contrast, has no rudders. Large vertical tails were fixed at the ends of the horizontal stabilizer, so turns were accomplished by ailerons alone. Control movements, of course, were restricted, to keep the aircraft from reaching unusual or excessive attitudes.

The Skyfarer was designed by noted MIT professor, Otto Kopper, who in later years developed the highly successful STOL Helio Courier. The Skyfarer was a metal frame, fabric covered air-

craft powered by a geared 75 hp. Lycoming engine. It carried a pilot and passenger, who were seated side by side. In size and speed performance it was comparable to contemporary Piper and Aeronca planes of the early forties. Like the Ercoupe, it had a tricycle landing gear, which was very uncommon at that time.

Skyfarers were produced by General Aircraft Corp., of Lowell, Mass. The period of production was very short, since, upon entry of the United States into the war, production was terminated. Thereafter, unfinished components, jigs, and the design were sold to a Michigan furniture builder. Production was never resumed.

It is likely that only a handful were built; I have been unable to ascertain the exact number. I saw only two. In 1941, at the very time I was developing my first Skyfarer model, a yellow, odd-shaped craft with large twin tails circled at low altitude over my boyhood community in Pennsylvania. On foot I raced off three miles to the local airfield, only to learn the Skyfarer had not landed. A few years later, while airport hopping for some winter sun, I spotted a Skyfarer at a Tampa, Florida airport. I was disappointed. It was in very tired condition and seemed ungainly, setting on its high tricycle gear. The twin tails reached very high. The spring on the nose gear was prominently ugly. Now that I ponder this remembrance after nearly three more decades, I recognize my reaction was excessively harsh. And it was undoubtedly influenced by the presence of my new, swift, sleek and shiny, fire-engine red Culver "V," which I had

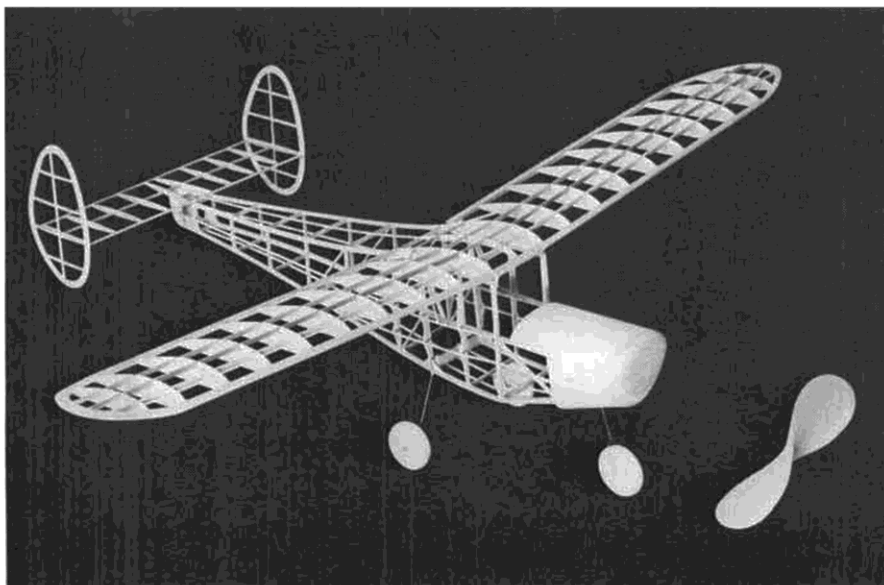

The last time we saw such neat workmanship was the last time we saw a model built by Earl Stahl. Same design was presented by Earl in a pre-war MAN, though it was to a smaller scale.



Air-to-air photo of the Skyfarer, taken by famous aviation photographer Rudy Arnold. Fins were fixed, and like the "Erpcup", the plane could not be over-controlled. The opening of World War II put an end to its career.

parked almost under the Skyfarer's left wing.

The Skyfarer is a fine model subject. It has a unique appearance, and the configuration is ideal for a rubber powered model. Aside from the necessity to provide wing dihedral, no alterations to shapes or areas are required. Even with a scale length landing gear, it accommodates a large propeller. This is my second Skyfarer model. The first was presented 34 years ago as one of a series of flying scale models I designed and tested for MODEL AIRPLANE NEWS. Many readers wrote to comment on their success with that early model. I flew the prototype until it almost wore out, and then I gave it to a neighborhood kid as I trooped off to war.

Featured here is a new model. It is somewhat larger than the first, being scaled one inch to the foot. Both of the models were developed from outline drawings, data, and photos provided by the manufacturer in 1941. (My 89 year old mother had preserved them, along with other memorabilia, in her attic. When she recently asked if I remembered they were there, I set a speed record making my way to her third floor.) If one compares the MODEL BUILDER drawings with three-view drawings which appeared in AERO DIGEST and AIRCRAFT YEAR BOOK of 1941, minor differences will be noted at the nose gear, in the door outline, and wing tip shape. I regard my drawings as correct, since they represent the aircraft as produced. The three-views in the other publications had likely been prepared from preliminary design information.

#### CONSTRUCTION

The primary fuselage structure is a

simple rectangular frame. Longerons are 1/8 sq., while uprights and cross members are 1/16 x 1/8. Build the two side frames, one atop the other to make sure they are identical. Because of the considerable curvature of the longerons, steaming or soaking in hot water will

aid in bending, and when dry, will help in preserving their accurate shape once they are lifted from the board. When assembling the sides over the top view, it will be necessary to crack the longerons so they can be pulled together, as intended, at the front.

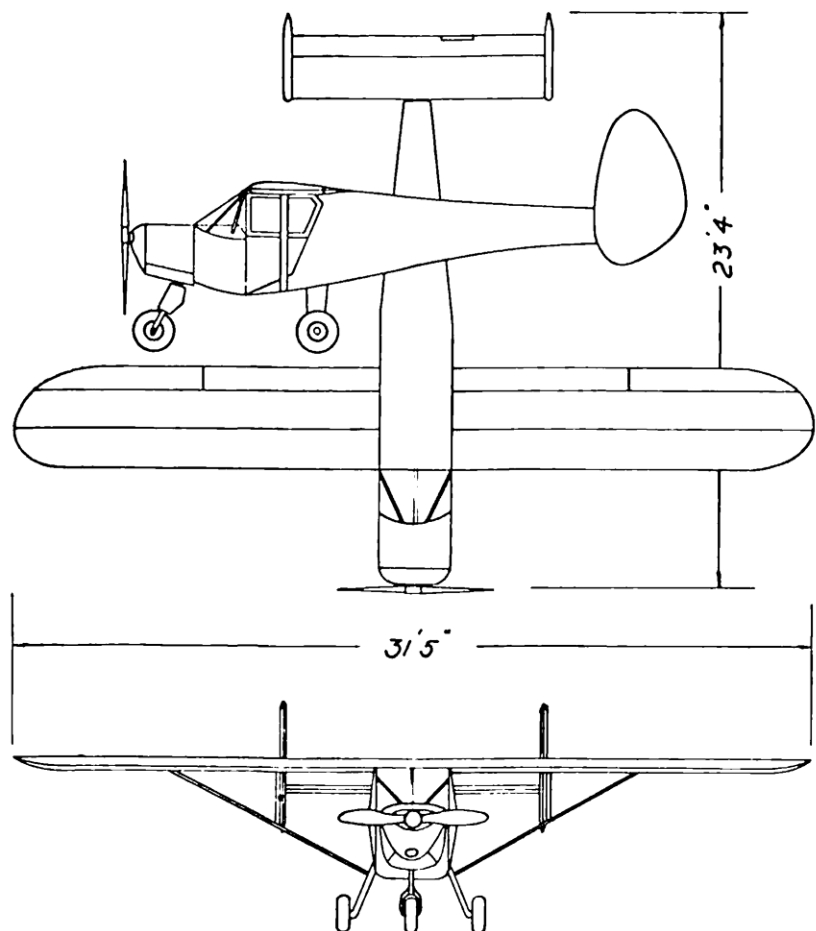



Earl has changed a little over the years, but his models sure haven't! This photo gives an idea of the model's 1 inch scale size.

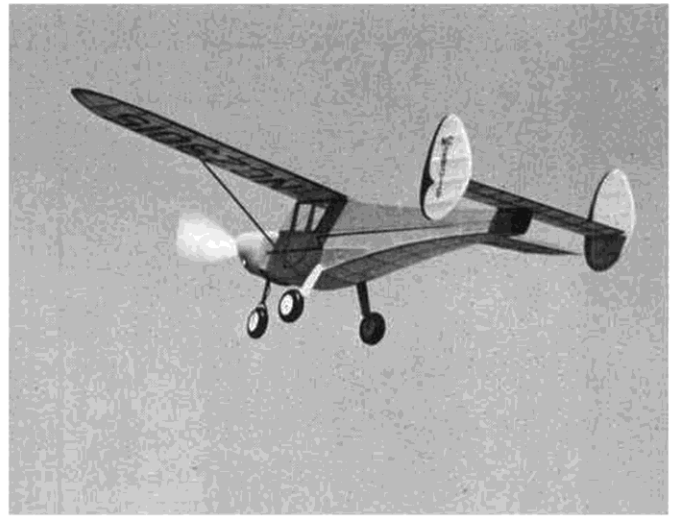

Doing the "up-up-and-away" bit, the Skyfarer makes an excellent flying scale subject. Hmmm . . . double the plans, add radio . . .

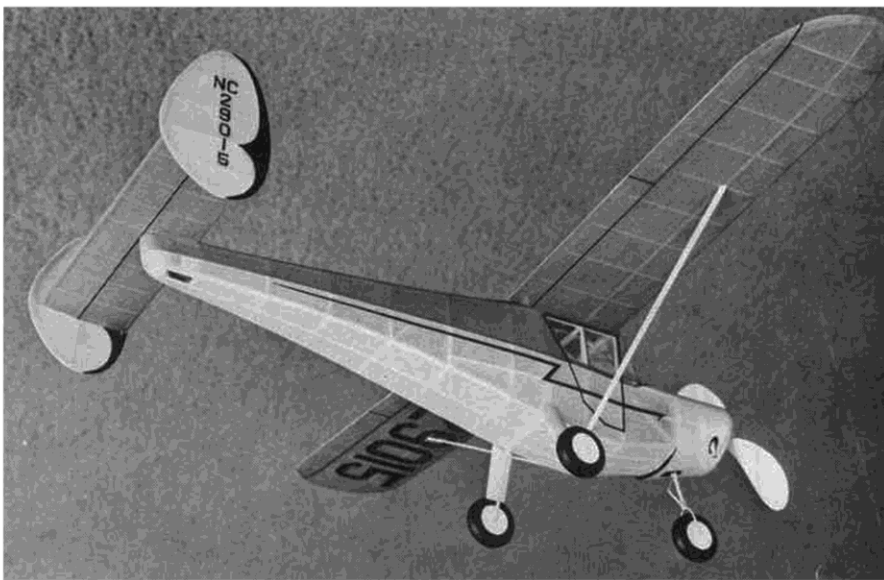

Drifting along under a low ceiling? No, hanging upside down over a carpet! This view shows off the landing gear detail and also indicates the excellent flying proportions. Note hole for rubber.

Formers cut from 1/16 light weight balsa give shape to the nose and fuselage sides. Assemble the wing center section over the plan, and then cement it atop the fuselage to make it an integral part . . . accurate positioning is important since it permanently sets the wing's location. Stringers are medium weight 1/16 sq. material; cement them in the notches of formers or to the sides of the primary structure. Formers F-6 through F-9 are sanded to the scalloped shape shown by the broken lines . . . this is done, as will be mentioned later, to allow tissue covering, to only contact longitudinal fuselage members. To accurately represent the fuselage shape, the outer edges of all longerons aft of station F-8 should be rounded.

Before the nose can be completed, the front landing gear fork must be attached. Bend the nose gear from two lengths of .034 music wire; join these parts with solder or epoxy. Position the nose gear assembly against former F-4; then with a needle and thread, sew it

into place. A liberal application of glue or epoxy completes the installation.

To simulate the metal engine cowling of the real craft, and to add strength, cover the nose with 1/32 sheet balsa. The area to be covered is represented on the drawing by wood grain shading. Use four or more individual pieces with the grain of each piece running parallel to the fuselage axis. Butt join the sections over stringers, and hold them in place with rubber bands and pins or masking tape until the cement hardens.

The extreme front of the nose is removable, to permit stretching the rubber motor for winding. Build up the nose block from laminations of 1/8 sheet balsa. Before roughly cutting the nose to shape, drill the hole for the propeller shaft and the larger hole for the nylon thrust bearing. Note that the thrust line is off-set for about four degrees of down-thrust. Tilting the thrust line slightly to the right is also advisable. Lightly cement the nose block to place for final contouring. Next remove the nose block,

and install a rectangular block on the back to accurately and snugly fit the primary structure of the nose. Glue a washer, or small metal plate with an .045 diameter hole at the back of the nose block to fix the thrust line. At this time, remove the centers of the primary fuselage cross-members under the top parts of formers F-1, F-2, and F-3, so they will not later interfere with the rubber motor.

Rear landing gear struts are formed from a single length of .040 music wire. First cement fuselage former F-10 to the primary structure, then bind and glue the wire gear to it as well as to the lower longerons. Attach the 1/16 triangular gussets between the longerons and uprights to strengthen the area.

Tail surfaces are next. They must be strong, yet remain very light. The stabilizer employs continuous lengths of 1/16 x 1/8 for the leading and trailing edges and spar. Cross members are 1/16 sq. Form ribs by cementing light weight 1/16 sq. strips to each side of each cross member; then trim and sand the ribs to a streamline shape. This is an easy task, and ribs can be made uniform in shape by using a narrow sanding block (longer than the stabilizer), and lightly working across all ribs at one time. As a concession to lightness, and to retain a flat surface to mate, at final assembly, with the stabilizer tips, make only the outside surface of each fin contoured by overlaying with 1/16 sq. strips.

Aside from the spars and trailing edges of the wing halves, which must be sturdy material, use light weight balsa for other parts. Taper the 1/8 x 3/8 trailing edges before commencing assembly; be assured they remain straight before committing them to the structure. Ribs are cut from 1/16 sheet. The tips are 3/16 thick, and they are best laminated to achieve the desired depth. Note that the tips are elevated so the top of the wing, when viewed from the front, is a straight line. As indicated on the

*Continued on page 72*

**Skyfarer . . . . Continued from page 29**

drawing, the aft portions of the tips are tapered to 1/8 inch thickness to match the trailing edge. Also observe that the inner ribs of each wing panel are tilted about four degrees from vertical, so dihedral will be correct upon assembly. Shape the leading edge and tip cross-sections to complete the wing frames.

For best flight performance, the model must be equipped with an efficient propeller. Select a hard, straight grain block 1 x 1-1/2 x 8-1/2 inches long. Before cutting the blank to shape, drill the hole for the shaft, a drill bit of about .045 inch diameter should be used. Carve a right hand prop, thinning the blades as much as practical consistent with strength requirements. Shape the blades using a paper pattern traced from one to make the other identical. Carefully sandpaper and balance the nearly completed propeller, then apply several coats of clear dope to produce a hard surface. A freewheel gadget, as shown on the drawing, may be made from thin brass or steel. Attach it with cement . . . likewise fix a washer or metal bearing surface on the back to make firm the shaft axis. This will enable the prop to spin freely once power is exhausted and thereby improve the glide.

Bend the propeller shaft from .040 inch music wire. Place several washers between the propeller and the nylon thrust bearing, and then bend a loop into the front of the shaft to which a mechanical winder can be hooked.

A neat, attractive covering job is a necessity for any fine flying scale model. Colored tissue is used, and since this was a general aviation aircraft, most any color scheme might be appropriate. Our test model is colored blue, yellow, black and silver, and it is eye-catching. Before starting to cover, every bit of the structure should be lightly, but thoroughly sanded to prepare for a quality job. Cellophane or other light plastic should be glued in place for the side windows. Keep in mind that only stringers and longerons should touch the tissue . . . cross-members should not. To avoid wrinkles, numerous small sections of tissue, carefully lapped, were used in completing the model pictured with this article. You may prefer to use the wet tissue method to cover compound surfaces. This procedure, as well as the use of thinned white glue in place of thinned dope, was described in detail in earlier issues of MODEL BUILDER. The balsa cowling and other exposed wood parts are covered with tissue also. Once covered, all parts are lightly sprayed with water to tighten the tissue. Flight surfaces should be restrained while drying to avoid warping. Do not apply dope to the covered parts until they have been assembled.

Commence assembly by checking the windshield pattern for exact fit to your model before cutting one from thin ac-

tate. Cement smears on the plastic must be avoided as they will mar the appearance. (*Hot Stuff is just the ticket for clean application of windows. wcn*)

Landing gear realism is created in this manner: Plastic tubing of the correct diameter is slit and slipped over the upper strut of the nose gear. Once the seam is recemented, thin diameter, tightly woven cord may be wrapped about the strut to simulate the real craft's compression spring. Tubing of thinner diameter is slipped over the fork halves. The fairings on the rear struts are cut from very light weight 1/4 inch sheet balsa. These fairings should be shaped to a streamline cross-section. Cut 1/8 inch deep grooves in the covers to conceal the wire struts. Epoxy the fairings to the wire, and then cover them with colored tissue. Note on the front view that the upper ends of the fairings are not attached to the adjacent fuselage structure. This will allow the struts to flex without marring the covering. Wheels are 1-9/16 inch diameter; they may be made from laminations of 1/8 inch sheet balsa.

Fins are cemented to the extremities of the stabilizer. Carefully remove the tissue covering from the insides of the fin ribs which will contact the stabilizer ends; this will permit a solid wood-to-wood juncture to be achieved for maximum strength. Also remove an appropriate amount of tissue from the center bottom of the stabilizer so the tail surfaces can be fitted to the rear fuselage at the correct position and angle.

Attach the wings to the center section with each tip elevated for 1-9/16 inch dihedral. Wing struts, 1/16 x 1/4, should be trimmed to a streamline shape, and then glued between the lower longerons and the lower wing spar and rib as shown on the drawing.

Trim details enhance the appearance greatly. License numerals, trim stripes, cowl openings, flap, aileron, and elevator outlines are all cut from contrasting tissue and attached by thinned dope. In completing the construction, brush on several coats of thinned clear dope, and paint bare wood surfaces with colored dope.

Ten to twelve strands of 1/8 inch flat rubber will probably be right to power your model. Lubricate the strands before dropping them through the fuselage. Remove a small section of tissue from the lower back of the fuselage for access to the rubber. Insert a bamboo dowel to retain the strands at the rear.

**FLYING**

Although you have constructed a model of sound design, maximum flying performance will require careful handling. First, adjust the center of gravity by adding weight to the nose or tail so the model balances about the lower wing spar. Select a calm day and a grassy field for testing. Achieve satisfactory hand glides before trying power. Adjust power

flights by tilting the thrust line down to eradicate any tendencies to stall, and sidewise to control the rate of turn. The Skyfarer is capable of smooth, long flights; building and flying one should become a rewarding and memorable experience. ●